

Thank you for purchasing a Beaver BS215 Stand!

Please read through the instructions carefully, prior to assembly, to help ensure the stand is easily and correctly put together.

PARTS LIST

NOTE: Please double check to ensure all parts are accounted for before discarding packaging.

Part Name	Ref Number	Order Number	Qty Required
Rectangular Base	309	50100090	1
Center Rod	315	55100017	1
Mounting Flange	316	50100010	1
Pipe	314	50100011	1
Tulip	313	50100013	1
Cushion Washer	312	50100014	1
Base Adapter	348	50100049	1
Crimp Nut	385	55100019	1
Feet (Pre-Installed)	382	50100091	4
Security Tether Kit	N/A	50160005	1

ONLY INCLUDED WITH BS215B (TWO MACHINES)

Double Bar	307	50100004	1
3/4" Carriage Bolts	387	5510005	4
1/4" x 20 Nut	4	55100010	4

ONLY INCLUDED WITH BS215C (THREE MACHINES)

Triple Bar	308	50100005	1
3/4" Carriage Bolts	387	5510005	4
1/4" x 20 Nut	4	55100010	4



Since 1963

Beaver Stand

[ASSEMBLY INSTRUCTIONS]

BS215 A27
[One Machine]

BS215 B27
[Two Machines]

BS215 C27
[Three Machines]

If you have any questions or require assembly assistance, please contact us for technical support.

BEAVER TECHNICAL SUPPORT

Phone: 905.836.4700 CDN & INT'L
800.265.6772 USA

Fax: 905.836.4737

Email: sales@beavervending.com

HOURS OF OPERATION

Monday – Thursday: 8AM – 4:30PM EST

WWW.BEAVERVENDING.COM

BS215 A27

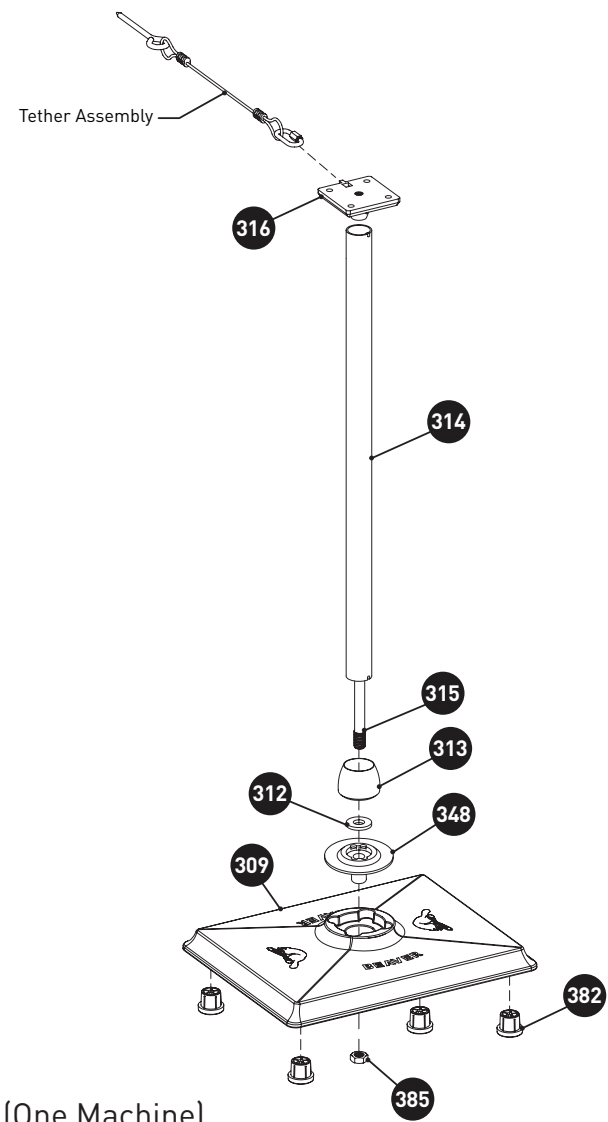

→ BS215 A27 (One Machine)

ASSEMBLY INSTRUCTIONS

REQUIRED TOOLS (NOT SUPPLIED): 3/4" WRENCH OR SOCKET AND 7/16" SOCKET

1. Take the Mounting Flange and Center Rod Assembly (316 & 315) and insert into the center of the Pipe (314).
 2. Place Cushion Washer (312) into the Base Adapter (348).
 3. Place the Base Adapter into the Base (309) recess.
 4. Line up dimples in the Pipe (314) and Tulip (313) so the Pipe will slide into the Tulip.
 5. Line up outward notches on Tulip (313) with the notches on the Base (309) recess, while confirming the mounting flange is facing head on to ensure the machine will face forward.
 6. Slide entire assembly into the Base (309).
 7. Place Nut (310) on the Center Rod (315) under the Base and tighten.
 8. Once the Nut (310) is tight, stand on the Base (309) and rock the Center Pipe (314) back and forth, then re-tighten the Nut (310). This helps ensure the Pipe will not loosen over time.
- NOTE: There will always be a small amount of sway. This helps to absorb shock, preventing the stand from breaking if mishandled.
9. Your stand is now assembled and ready to have the Machines and Security Tether installed. Please see detailed installation instructions included with these components.

BS215 B27

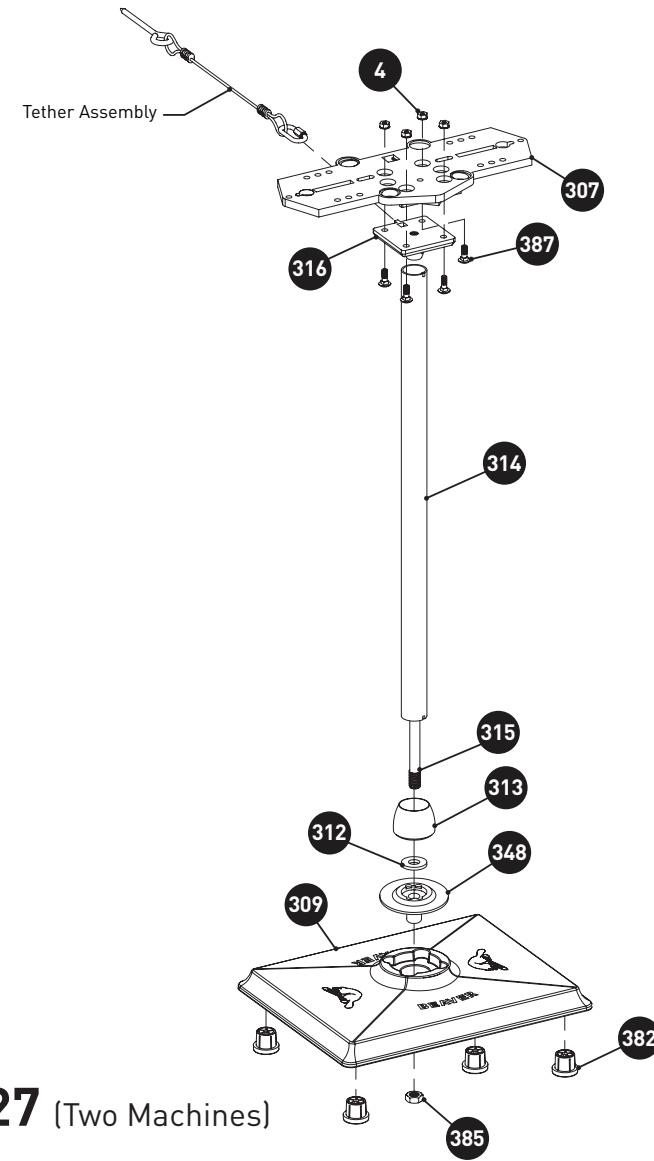

→ BS215 B27 (Two Machines)

ASSEMBLY INSTRUCTIONS

REQUIRED TOOLS (NOT SUPPLIED): 3/4" WRENCH OR SOCKET AND 7/16" SOCKET

1. Take the Mounting Flange and Center Rod Assembly (316 & 315) and insert into the center of the Pipe (314).
 2. Place Cushion Washer (312) into the Base Adapter (348).
 3. Place the Base Adapter into the Base (309) recess.
 4. Line up dimples in the Pipe (314) and Tulip (313) so the Pipe will slide into the Tulip.
 5. Line up outward notches on Tulip (313) with the notches on the Base (309) recess, while confirming the Mounting Flange is facing head on to ensure the machine will face forward.
 6. Slide entire assembly into the Base (309).
 7. Place Nut (310) on the Center Rod (315) under the Base and tighten.
 8. Once the Nut (310) is tight, stand on the Base (309) and rock the Center Pipe (314) back and forth, then re-tighten the Nut (310). This helps ensure the Pipe will not loosen over time.
- NOTE: There will always be a small amount of sway. This helps to absorb shock, preventing the stand from breaking if mishandled.
9. Place the Double Bar (307) on top of the Flange (316). Insert the four 3/4" Carriage Bolts (387) from the bottom of the Flange (316), and use the four 1/4 x 20 nuts (4) to secure the bar to the Flange.
 10. Your stand is now assembled and ready to have the machines and Security Tether installed. Please see detailed installation instructions included with these components.

BS215 C27

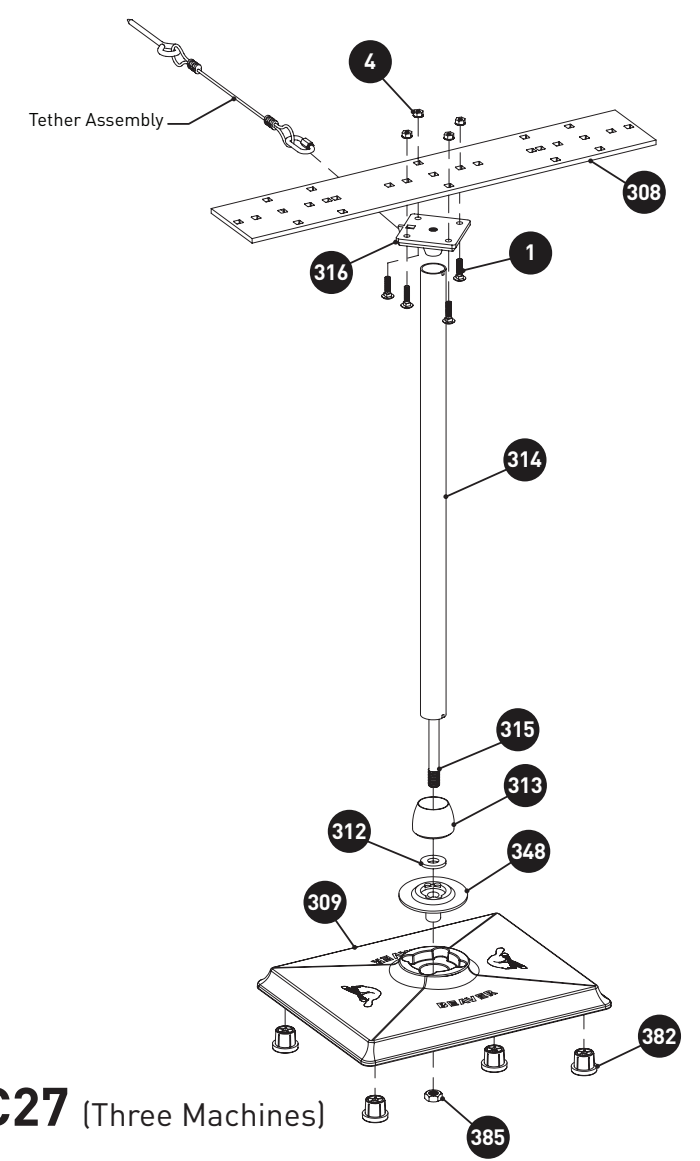

→ BS215 C27 (Three Machines)

ASSEMBLY INSTRUCTIONS

REQUIRED TOOLS (NOT SUPPLIED): 3/4" WRENCH OR SOCKET AND 7/16" SOCKET

1. Take the Mounting Flange and Center Rod Assembly (316 & 315) and insert into the center of the Pipe (314).
2. Place Cushion Washer (312) into the Base Adapter (348).
3. Place the Base Adapter into the Base (309) recess.
4. Line up dimples in the Pipe (314) and Tulip (313) so the Pipe will slide into the Tulip.
5. Line up outward notches on Tulip (313) with the notches on the Base (309) recess, while confirming the Mounting Flange is at a 45° angle to ensure the machine will face forward one mounted.
6. Slide entire assembly into the Base (309).
7. Place Nut (310) on the Center Rod (315) under the Base and tighten.
8. Once the Nut (310) is tight, stand on the Base (309) and rock the Center Pipe (314) back and forth, then re-tighten the Nut (310). This helps ensure the Pipe will not loosen over time. NOTE: There will always be a small amount of sway. This helps to absorb shock, preventing the stand from breaking if mishandled.
9. Place the Triple Bar (308) on top of the Flange (316) at a 45° angle to the Flange (parallel to the Base), matching to the holes of the Triple Bar. Insert the four 3/4" Carriage Bolts (387) from the bottom of the Flange (316), and use the four 1/4 x 20 nuts to secure the bar to the Flange. NOTE: If the Flange is not on a 45° angle, the machines will be on an angle to the stand Base (309).
10. Your stand is now assembled and ready to have the machines and Security Tether installed. Please see detailed installation instructions included with these components.